



24" (609.6mm) FULL OPENING MANHOLE

ASME TYPE

ASME SYMBOL & DATA PROVIDED
 THREADED HOLD-DOWNS
 6" OR 10" HIGH COLLAR AVAILABLE



1.800.527.8775

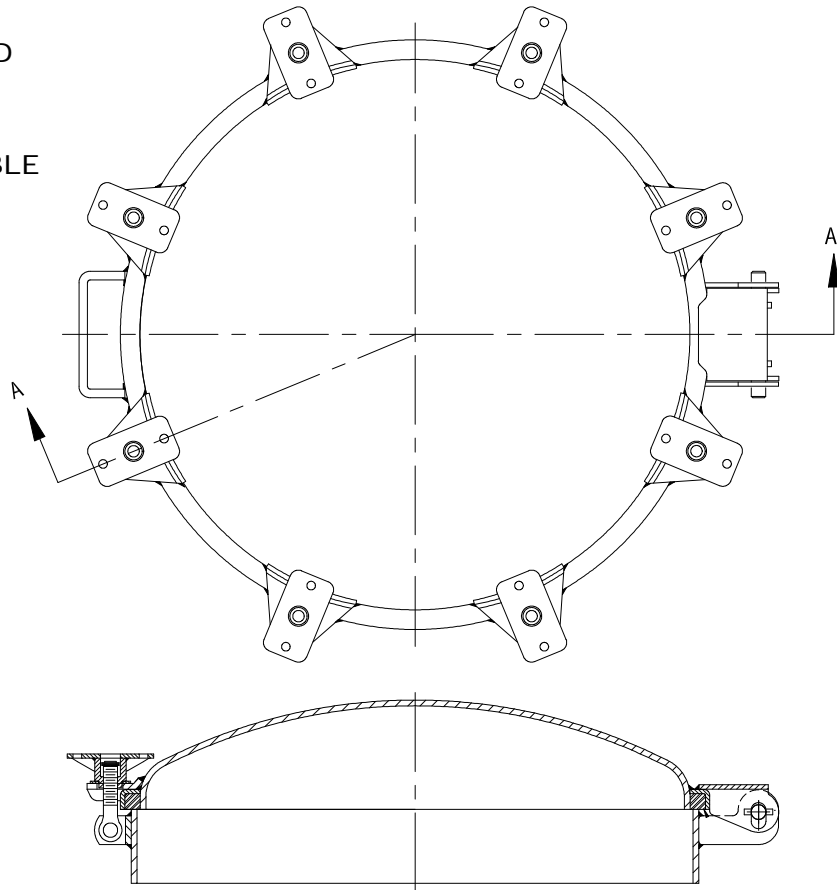

Section A-A
 Model 8324

This Tiona 24" Full Opening Manhole conforms to the requirements of the ASME code for pressure vessels Section VIII, Division 1.

Weld Collar	Cover	Wing-Nut Washer Hinge Pins	Number Hold Downs	*Working Pressure		Weight	Collar Height	Assembly No.
				100 PSI	6.8 BAR			
Steel	Steel	Stnls 304	8	100 PSI	6.8 BAR	100LB 45.5Kg	6" (152.4mm)	8324SCW-6"
Stnls 316L	Stnls 316L	Stnls 304						8324LCW-6"
Steel	Steel	Stnls 304	8	100 PSI	6.8 BAR	125LB 56.9Kg	10" (254mm)	8324SCW-10"
Stnls 316L	Stnls 316L	Stnls 304						8324LCW-10"

Canadian Registration Number OH0344.0123456789

Notes: White Hypalon gasket furnished as standard (reference suffix "W" in assembly number). For other gaskets available, see parts page for correct suffix.

*Tests were conducted and ratings determined with homogeneous gaskets

During installation and welding the collars to the tank, care should be exercised to insure the collars remain flat and round in order to assure proper performance. If necessary a welding fixture should be used to prevent distortion.

PARTS LIST

24" (609.6mm) FULL OPENING MANHOLE
ASME TYPE

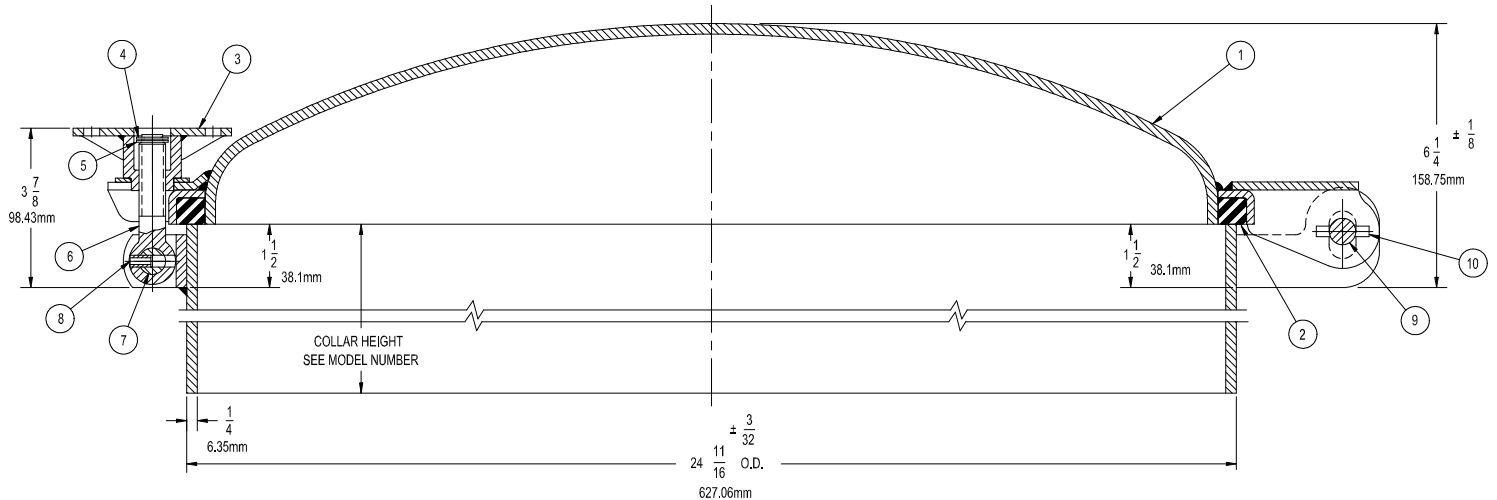

No.	Description	Material	Part No.
1	Cover	Steel	6455FB
		Stnls 316L	6455LC
2	Gasket*	B Buna-N	3907BN
		V Viton	3907VT
		W White Hypalon	3907WH
		E White Non-Asbestos with Teflon Suspensoid (Woven)	3907NT

No.	Description	Material	Part No.
3	Wing Nut	Stnls 304	3576SL
4	Snap Ring	Stnls 304	9Q4933
5	Snap Ring Washer	Stnls 304	3575SL
6	Swing Bolt	Stnls 17/4 PH	4102SF
7	Swing Bolt Pin	Stnls 304	3086SL
8	Roll Pin-Swg Bolt	Stnls 304	9Q8593
9	Hinge Pin	Stnls 304	3818SL
10	Roll Pin-Hinge Pin	Stnls 304	9Q8594

*Gasket Maximum Temperature

Buna-N (Nitrile)	250°F
Viton	400°F
White Hypalon	250°F
White Non-Asbestos with Teflon Suspensoid	500°F

GASKETS:

Check the condition of all gaskets and replace if their effectiveness as a seal is impaired in any way. Replacement gaskets must be compatible with products carried.

MAINTENANCE:

Manhole assembly should be inspected with sufficient frequency and with due regard to the products carried to insure a liquid tight closure. Any worn, damaged, or missing parts must be replaced.

WING NUTS AND SWING BOLTS:

All swing bolt and wing nut assemblies must be secured to the cover and tightened to insure the pressure and product retention performance of the manhole assembly.

WARNING Use only genuine Betts Industries Inc. replacement parts. Use of substitute parts can impair the proper functioning of this product.